

CARACTERISTICAS / FEATURES

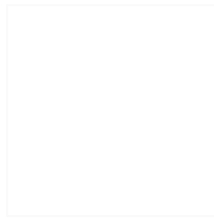

**Material** hormigón Petra 1  
**Acabado** decapado e hidrofugado  
**Dimensiones** Ø 110, h. 90 cm  
**Color** ver carta de colores  
**Fijación** apoyado por su propio peso  
**Peso** 452 kg / 485 L  
**Palet** 120 x 120 cm

**Material** precast concrete Petra 1  
**Finish** scaled and waterproofed  
**Dimensions** Ø 110, h. 90 cm  
**Colour** see colour catalogue  
**Fixing** resting on the ground  
**Weight** 452 kg / 485 L  
**Pallet** 120 x 120 cm

diseñador / design: magourban

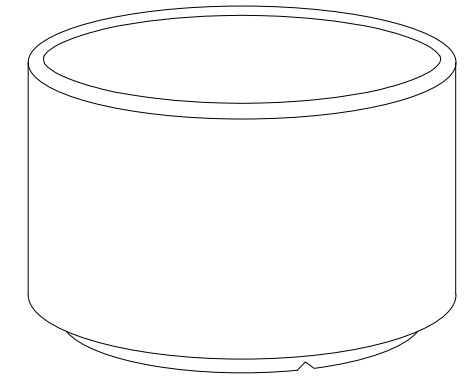

CIRCULAR BIG

GEOMETRIA / GEOMETRY

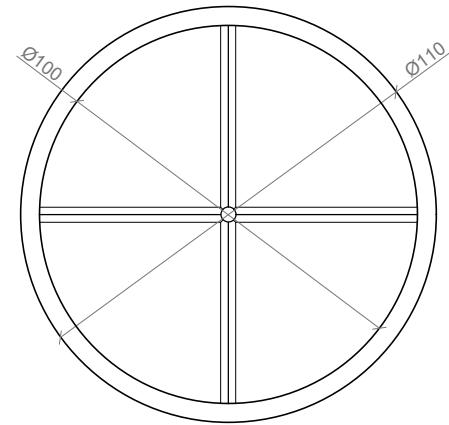

VISTA INFERIOR / BOTTOM VIEW

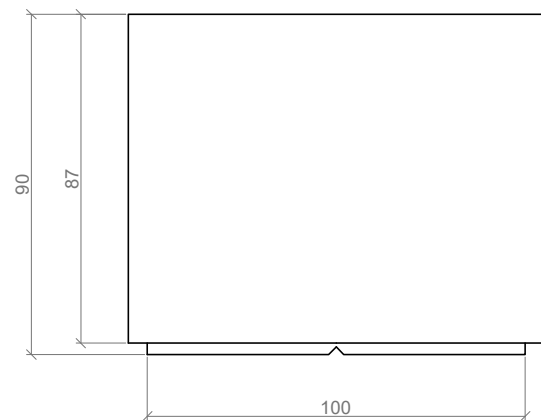

ALZADO / FRONT VIEW

ESC. 1:20

MANIPULACION E INSTALACION / HANDLING AND INSTALLATION

- 1 Fijar eslingas e instalar / Fixing slings and install.

Elevación / Hoisting  
 P= 452 kg

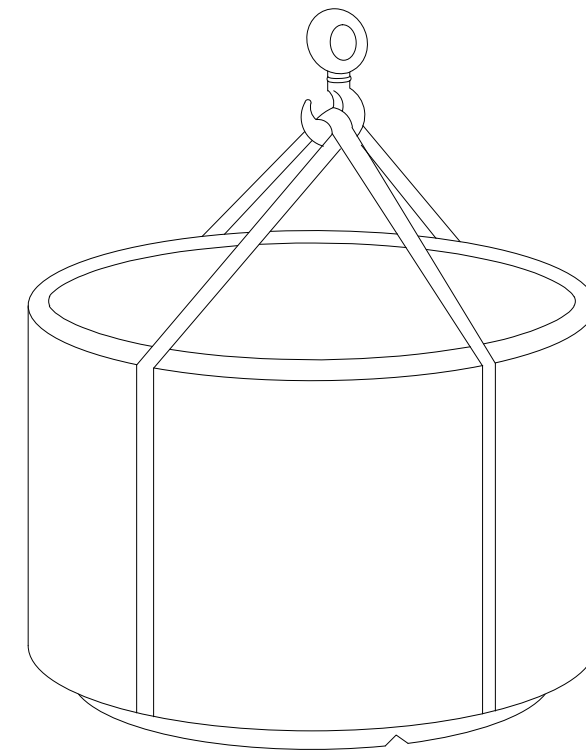

ESPECIFICACIONES / SPECIFICATIONS

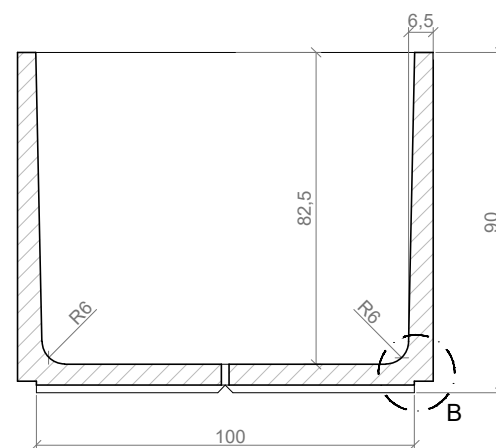

SECCION A-A' / SECTION A-A'

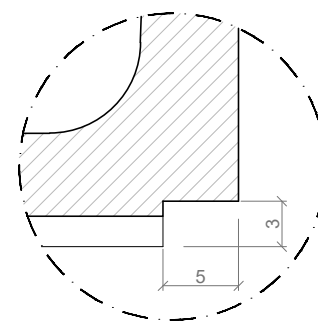

DETALLE B / DETAIL B

ESC. 1:20