

CARACTERISTICAS / FEATURES

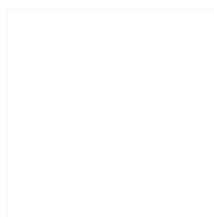

Material hormigón Petra 1
Acabado decapado e hidrofugado
Dimensiones Ø 90, h. 52 cm
Color ver carta de colores
Fijación apoyado por su propio peso
Peso 218 kg / 228 L
Palet 100 x 100 cm

Material precast concrete Petra 1
Finish scaled and waterproofed
Dimensions Ø 90, h. 52 cm
Colour see colour catalogue
Fixing resting on the ground
Weight 218 kg / 228 L
Pallet 100 x 100 cm

diseñador / design: magourban

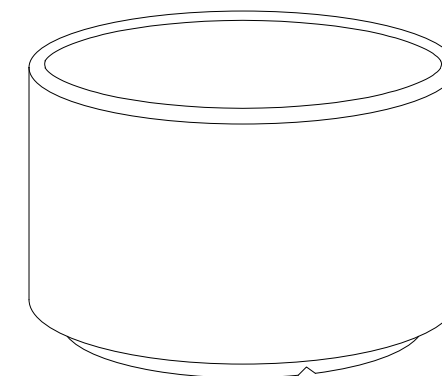

CIRCULAR SMALL

GEOMETRIA / GEOMETRY

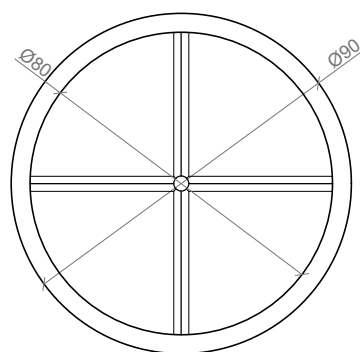

VISTA INFERIOR / BOTTOM VIEW

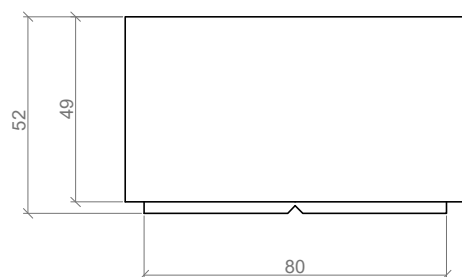

ALZADO / FRONT VIEW

ESC. 1:20

MANIPULACION E INSTALACION / HANDLING AND INSTALLATION

- 1 Fijar eslingas e instalar / Fixing slings and install.

Elevación / Hoisting
 P= 218 kg

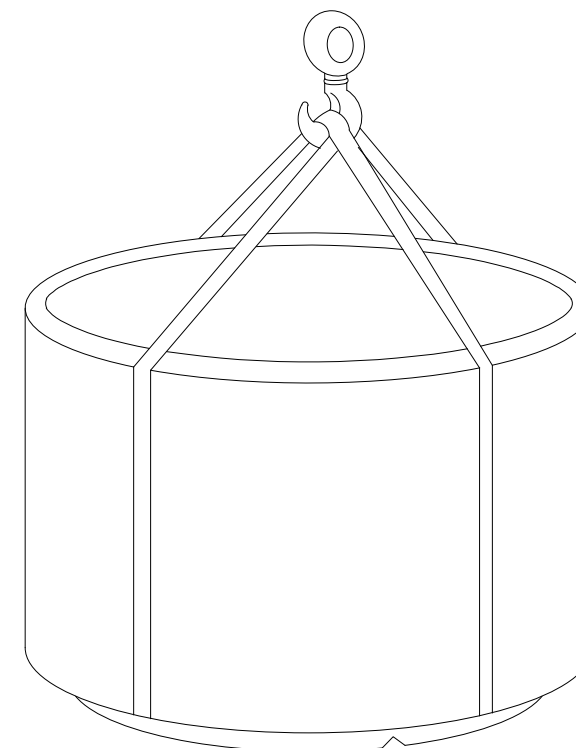

ESPECIFICACIONES / SPECIFICATIONS

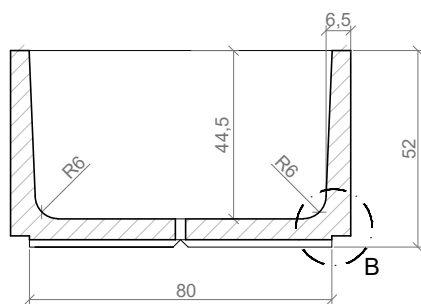

SECCION A-A' / SECTION A-A'

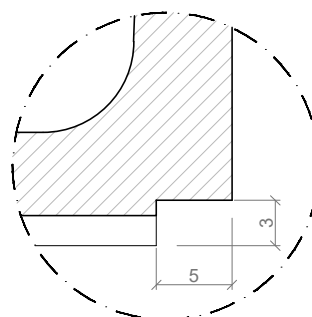

DETALLE B / DETAIL B

ESC. 1:20